

FLPP1G

Available in:
White, Black, Matt White, Matt Black
and Brushed Aluminium

Cleaning Guide:

Spraying cleaning products directly on to electrical switches or power points (sockets) is not recommended.

It is important to ensure that switches are turned off before cleaning.

Do not use any cleaning sprays - only wipe down with damp cloth or rub with dry cloth. Do not use an abrasive cloth as it may scratch the plastic.

Do not use harsh chemical cleaners as these can break down the plastic and cause it to crack.

Do not wash the cover plates in water over 60°C.

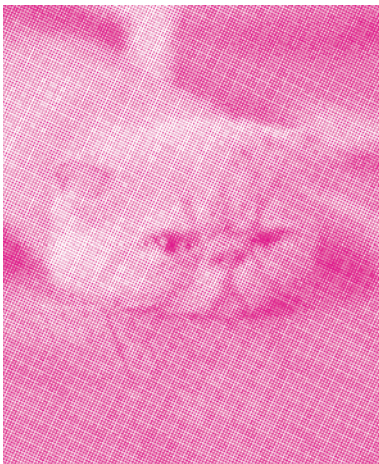

Flat Cat Range of Single Power Points

- Switches approved to AS/NZS3133
- Socket outlets approved to AS/NZS3112
- Uses brass tunnel terminals that have the screws backed out for easier installation of cabling. Power point terminals have 5.8mm bore to suit 4 x 2.5mm² cable
- Fits recessed Australian wall boxes and mounting accessories that use 84mm mounting centres
- Covers, plates and dollies are made from UV stabilised polycarbonate to avoid discolouring to yellow
- Standard colour is White. Also available in Matt White, Black, Matt Black & Brushed Aluminium - please check availability
- Typical example of size seen below:

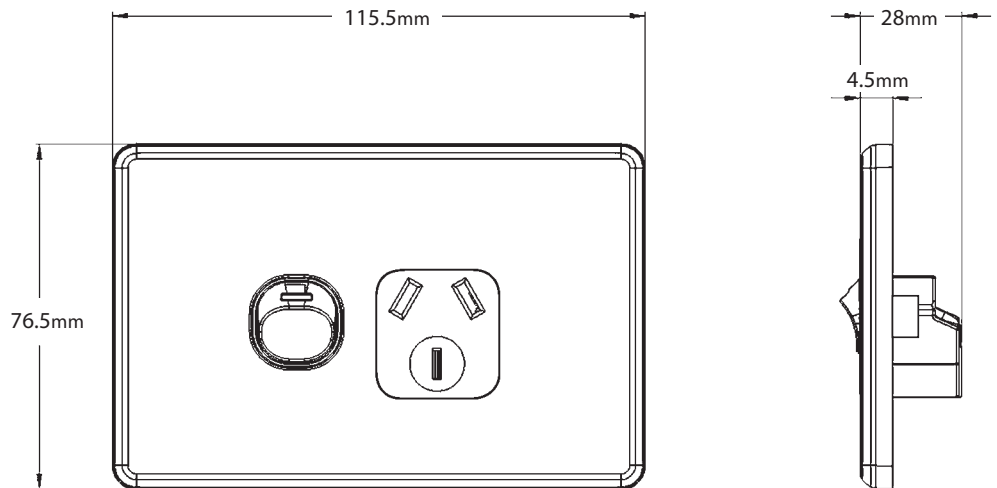

Catalogue Number	Description
FLPP1G	Power Point Switched 1 Gang 10A 250V~

When ordering **BLACK** product add "**BK**" to end of catalogue number, ie FLPP1GBK

When ordering **MATT BLACK** product add "**MBK**" to end of catalogue number, ie FLPP1GMBK

When ordering **MATT WHITE** product add "**MW**" to end of catalogue number, ie FLPP1GMW

When ordering **BRUSHED ALUMINIUM** (cover) add "**CBA**" to end of catalogue number, ie FLPP1GCBA

Certification Number:

FLPP1G: GMA-103194-EA-016

GSM Electrical (Australia) Pty Ltd

Level 2, 142-144 Fullarton Road, Rose Park SA 5067

P: 1300 301 838 F: 1300 301 778 E: service@gsme.com.au

www.gsme.com.au



FLPP2G FLPPSW2G

Available in:
White, Black, Matt White, Matt Black
and Brushed Aluminium

Cleaning Guide:

Spraying cleaning products directly on to electrical switches or power points (sockets) is not recommended.

It is important to ensure that switches are turned off before cleaning.

Do not use any cleaning sprays - only wipe down with damp cloth or rub with dry cloth. Do not use an abrasive cloth as it may scratch the plastic.

Do not use harsh chemical cleaners as these can break down the plastic and cause it to crack.

Do not wash the cover plates in water over 60°C.

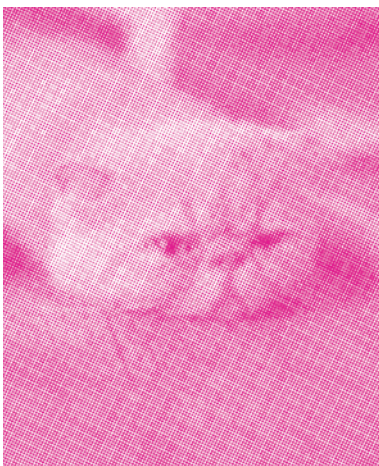

Flat Cat Range of Double Power Points

- Switches approved to AS/NZS3133 or AS/NZS60669
- Socket outlets approved to AS/NZS3112
- Uses brass tunnel terminals that have the screws backed out for easier installation of cabling. Power point terminals have 5.8mm bore to suit 4 x 2.5mm² cable
- Fits recessed Australian wall boxes and mounting accessories that use 84mm mounting centres
- Covers, plates and dollies are made from UV stabilised polycarbonate to avoid discolouring to yellow
- Standard colour is White. Also available in Matt White, Black, Matt Black & Brushed Aluminium - please check availability
- Typical example of size seen below:

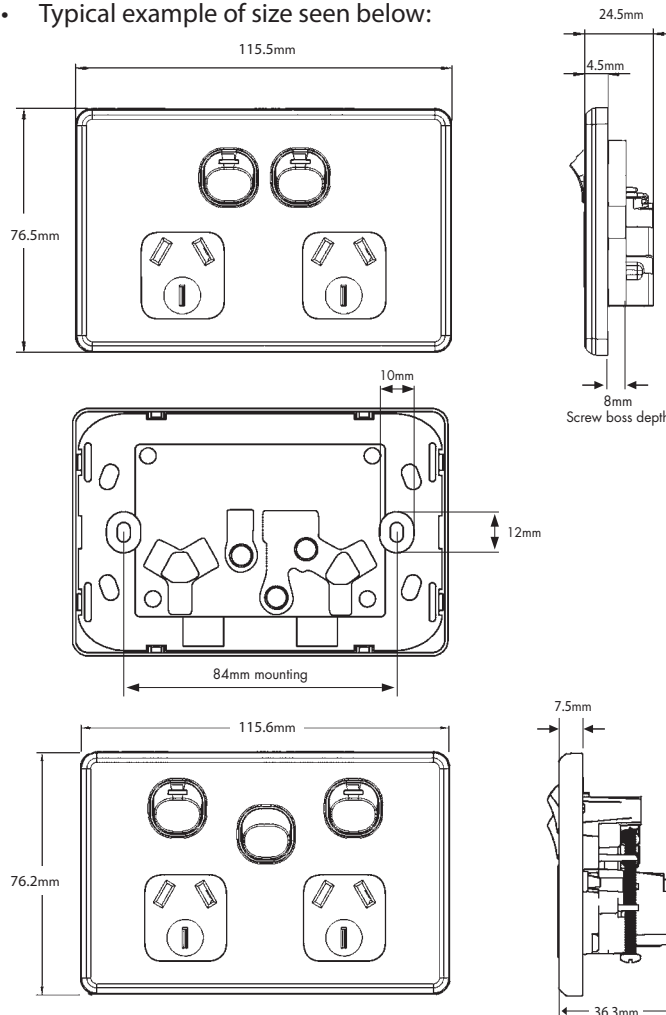

Catalogue Number	Description
FLPP2G	Power Point Switched 2 Gang 10A 250V~
FLPPSW2G	Power Point Switched 2 Gang 10A 250V~ With Removable Extra Switch 16AX/20A

When ordering **BLACK** product add "BK" to end of catalogue number, ie FLPP1GBK

When ordering **MATT BLACK** product add "MBK" to end of catalogue number, ie FLPP1GMBK

When ordering **MATT WHITE** product add "MW" to end of catalogue number, ie FLPP1GMW

When ordering **BRUSHED ALUMINIUM** (cover) add "CBA" to end of catalogue number, ie FLPP1GCBA

Certification Number: GMA-502069-EA

GSM Electrical (Australia) Pty Ltd

Level 2, 142-144 Fullarton Road, Rose Park SA 5067

P: 1300 301 838 F: 1300 301 778 E: service@gsme.com.au

www.gsme.com.au



- FLSWV1G
- FLSWV2G
- FLSWV3G
- FLSWV4G
- FLSWV5G
- FLSWV6G
- FLSW1G
- FLSW2G
- FLSW3G
- FLSW4G
- FLSW5G
- FLSW6G
- FLSWPV1G
- FLSWPV2G
- FLSWPV3G
- FLSWPV4G
- FLSWPV5G
- FLSWPV6G
- FLSWPVXG

Available in:
White, Black, Matt White, Matt Black
and Brushed Aluminium

Cleaning Guide:

Spraying cleaning products directly on to electrical switches or power points (sockets) is not recommended.

It is important to ensure that switches are turned off before cleaning.

Do not use any cleaning sprays - only wipe down with damp cloth or rub with dry cloth. Do not use an abrasive cloth as it may scratch the plastic.

Do not use harsh chemical cleaners as these can break down the plastic and cause it to crack.

Do not wash the cover plates in water over 60°C.

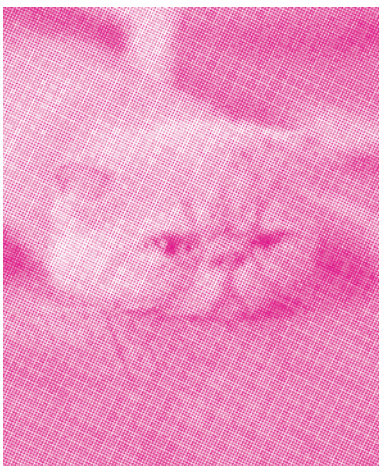

Flat Cat Range of Switch Plates

- Switches are rated 10AX/16A 250V~ and approved to AS/NZS3133
- Fits recessed Australian wall boxes and mounting accessories that use 84mm mounting centres
- Uses brass tunnel terminals that have the screws backed out for easier installation of cabling. Switches are two way with looping terminal and suit 4 x 1.5mm² cabling with 4.1 bore
- Slotted head screws for the terminals
- Covers, plates and dollies are made from UV stabilised polycarbonate to avoid discolouring to yellow
- Standard colour is White. Also available in Matt White, Black, Matt Black & Brushed Aluminium - please check availability
- Plates suit Trader Meerkat MESW mechs, including TV and Data; and Clipsal 30 Style* mechs and accessories
- Typical example of size seen below:

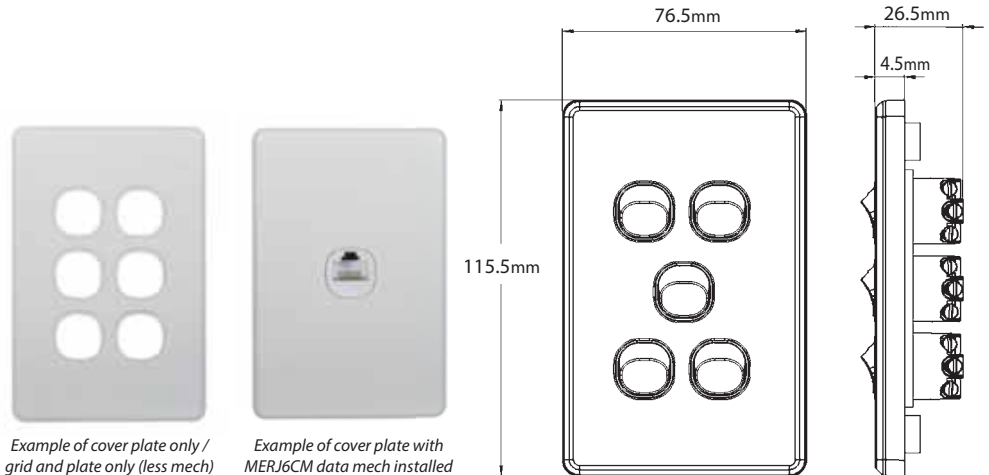

Example of cover plate only / grid and plate only (less mech)

Example of cover plate with MERJ6CM data mech installed

Catalogue No.	Description
FLSWV1G	Switch Vertical 1 Gang, 10AX/16A 250V~
FLSWV2G	Switch Vertical 2 Gang, 10AX/16A 250V~
FLSWV3G	Switch Vertical 3 Gang, 10AX/16A 250V~
FLSWV4G	Switch Vertical 4 Gang, 10AX/16A 250V~
FLSWV5G	Switch Vertical 5 Gang, 10AX/16A 250V~
FLSWV6G	Switch Vertical 6 Gang, 10AX/16A 250V~
FLSW1G	Switch Horizontal 1 Gang, 10AX/16A 250V~
FLSW2G	Switch Horizontal 2 Gang, 10AX/16A 250V~
FLSW3G	Switch Horizontal 3 Gang, 10AX/16A 250V~
FLSW4G	Switch Horizontal 4 Gang, 10AX/16A 250V~
FLSW5G	Switch Horizontal 5 Gang, 10AX/16A 250V~
FLSW6G	Switch Horizontal 6 Gang, 10AX/16A 250V~

Horizontals available by request

When ordering **BLACK** product add "BK" to end of catalogue number, ie FLPP1GBK

When ordering **MATT BLACK** product add "MBK" to end of catalogue number, ie FLPP1GMBK

When ordering **MATT WHITE** product add "MW" to end of catalogue number, ie FLPP1GMW

When ordering **BRUSHED ALUMINIUM** (cover) add "CBA" to end of catalogue number, ie FLPP1GCBA

Catalogue No.	Description
FLSWPV1G	Switch Plate Vertical 1 Gang (Less Mech)
FLSWPV2G	Switch Plate Vertical 2 Gang (Less Mech)
FLSWPV3G	Switch Plate Vertical 3 Gang (Less Mech)
FLSWPV4G	Switch Plate Vertical 4 Gang (Less Mech)
FLSWPV5G	Switch Plate Vertical 5 Gang (Less Mech)
FLSWPV6G	Switch Plate Vertical 6 Gang (Less Mech)
FLSWPVXG	Blank plate with clip on surround

The above catalogue numbers where "P" appears in number, refers to Cover Plate Only / Grid and Plate only (less mech)

* The Clipsal brand and associated products are Trademarks of Schneider Electric (Australia) Pty Ltd.

GSM Electrical (Australia) Pty Ltd, the TRADER brand and it's products, have no endorsement or affiliation with Schneider Electric Pty Ltd.



MEERKAT Switch Mechanisms are used for all switch plates. Please refer to Meerkat Mech Matrix for range compatibility.

Certification Number: GMA-103194-EA-011

GSM Electrical (Australia) Pty Ltd

Level 2, 142-144 Fullarton Road, Rose Park SA 5067

P: 1300 301 838 F: 1300 301 778 E: service@gsme.com.au

www.gsme.com.au

