

## PUPP2GSK

\*See current catalogue for further detail

### Cleaning Guide:

Spraying cleaning products directly on to electrical switches or power points (sockets) is not recommended.

It is important to ensure that switches are turned off before cleaning.

Do not use any cleaning sprays - only wipe down with damp cloth or rub with dry cloth. Do not use an abrasive cloth as it may scratch the plastic.

Do not use harsh chemical cleaners as these can break down the plastic and cause it to crack.

Do not wash the cover plates in water over 60°C.



## Puma Double Power Point, Skirting Mount

- The Double Power Point assembly consists of two single sockets that are looped together (loops are included).
- The slim design is ideal for skirting board applications or thin timber panel mounting where space is an issue.
- The styling of the plate aligns with the rest of the PUMA range.
- The socket is only available in single pole format.
- Slim profile of 54mm high.
- Depth into the wall including the wire loops is 26mm.
- 135mm mounting centres.
- Length overall with cover 160mm.
- Available in White.

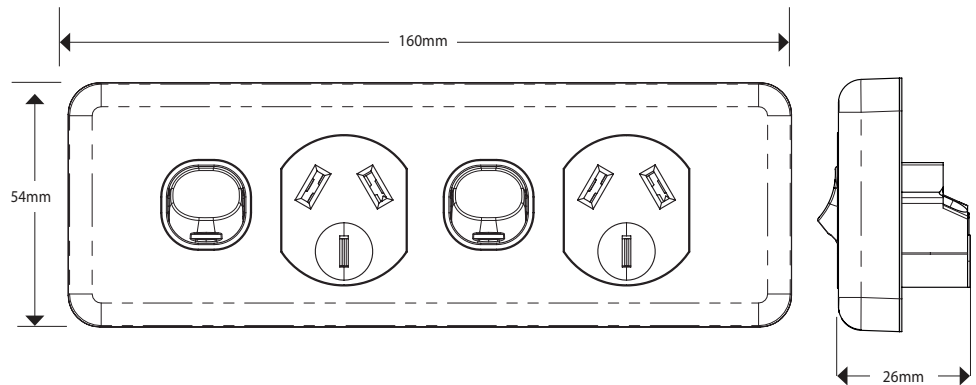

Catalogue Number	Description
PUPP2GSK	Power Point Switched 2 Gang, Skirting Mount, 10A 250V~

**Certification Number:**  
TBC

**GSM Electrical (Australia) Pty Ltd**  
Level 2, 142-144 Fullarton Road, Rose Park SA 5067  
P: 1300 301 838 F: 1300 301 778 E: service@gsme.com.au  
[www.gsme.com.au](http://www.gsme.com.au)



Data Specification Sheet  
September 2021