

# Gleam Recessed LED Downlight Installation Instructions



## Product Specifications

Model No.	HV5529D2W-BLK	HV5529D2W-BB	HV5529D2W-BC	HV5529D2W-BG	HV5529D2W-WHT	HV5529D2W-WB	HV5529D2W-WC	HV5529D2W-WG	HV5529D2W-WW
Name	Gleam								
Material	Polycarbonate Face with Aluminium Body								
Colour	Black	Black + Black Insert	Black + Chrome Insert	Black + Gold Insert	White	White + Black Insert	White + Chrome Insert	White + Gold Insert	White + White Insert
Installation Type	Recessed - Ceiling								
Cut Out	Ø90mm								
IC Rating	IC-4 when used with HV5528-IC4CAP (Fitting Only - Driver cannot be installed under insulation)								
IP Rating	IP54 - Front of fitting only								
Input Voltage	240v AC - Separate Driver with Flex & plug								
Protection Class	2 (No Earth Required) <input type="checkbox"/>								
Lamp Base	Built in LED								
Lamp Wattage	1x 9w								
Colour Temp	Dim to Warm - 1800k-3000k								
Lumens	685lm								
CRI	>80								
Dimmable	Yes - Triac								
Warranty	3 Years Replacement*								

### Dimensions:

Cut Out Ø76

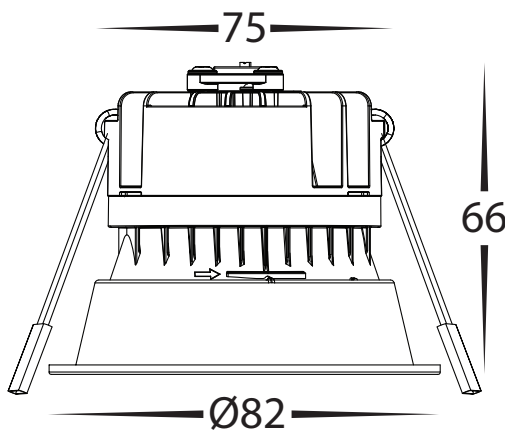

### Dimensions with IC Cap:

Cut Out Ø76

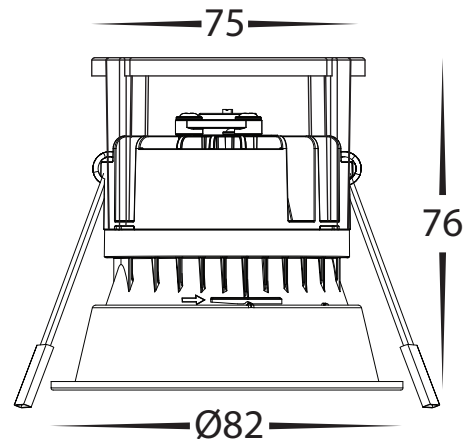

### Important Safety Issues:

- This product must be installed by a qualified electrician according to AS/NZS 3000.
- Ensure all electrical mains are disconnected before any installation.
- Modification of this product will void any warranty.
- Havit Lighting does not take responsibility for wrong installation, incorrect use, or use of installation material that does not belong to the system.
- Aluminium and 304SS fittings must not be installed within 5km of any salt water environments.
- Only LED Fitting can be installed under insulation, LED Driver must not be covered to allow for ventilation.
- This fixture must not be installed with loose fill insulation such as macerated paper and wool. LED driver must be mounted above any insulation covering the fixture.
- These instructions may be updated at any time due to product improvements. Please visit website for most current installation instructions.

### Installation Diagram:

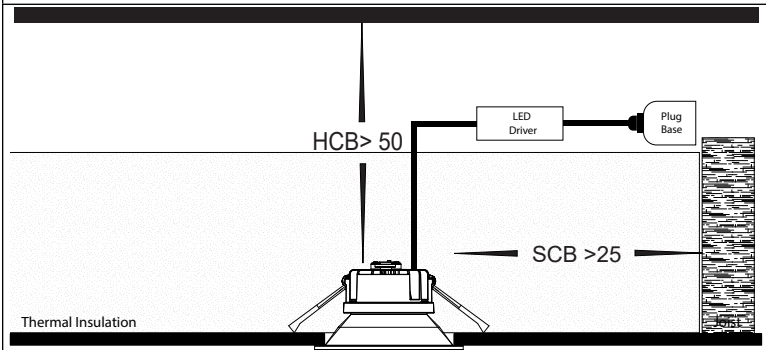

### Steps for Installation:

1. Make sure that the electrical circuit is free of voltage (master switch off)
2. Cut out hole using dimensions in table above making sure each hole is not under joists or pipes.
3. Fitting is provided with flex and plug, Plug cable into plug base installed earlier.
4. If HV5528-ICCAP is being used, Clip onto back of fitting.
5. Pull back springs on fitting and insert into hole.
6. Once fitting is in hole, release clips onto back of ceiling, These springs will hold fitting in place.
7. All connections must be carried out carefully, inspect all contacts before switching back on the electric circuit.
8. To achieve Dim to Warm settings a Triac/Phase cut dimmer needs to be used, Refer Dimmer instructions for connection method

## Must be installed by a licensed electrician

### Contact Details:

143 Beauchamp Road  
Matraville NSW 2036  
Australia

Tel: 02 9381 8300  
Fax: 02 9666 8881  
Email: sales@havit.com.au  
Web: www.havit.com.au

### Warranty Terms & Conditions\*



www.havit.com.au

