

60WS IP66 Slimline Weatherproof LED Driver

Material	Aluminium
Colour	Silver
IP Rating	IP66
Input Voltage	240v AC
Output Voltage	Available in either 12v DC or 24v DC
Max Wattage	60w (Recommended Max Wattage = 48w)
Protection Class	1 (Earth Required)
Wiring	Parallel
No. Output Cables	1
Protections	Short Circuit, Overload, Over Temperature
Warranty	3 Years Replacement

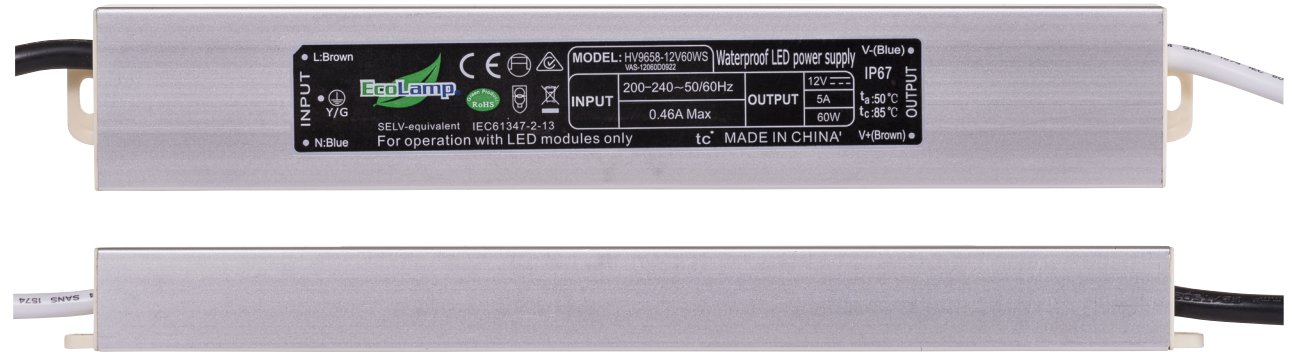

Compatible with

All Low Voltage Light Fittings & LED Strip



Product Ordering

Part Number	Output Voltage	Barcode
HV9658-12V60WS	12v DC Constant Voltage	9350418008503
HV9658-24V60WS	24v DC Constant Voltage	9350418008527



Website



Warranty
Terms & Conditions

Dimensions

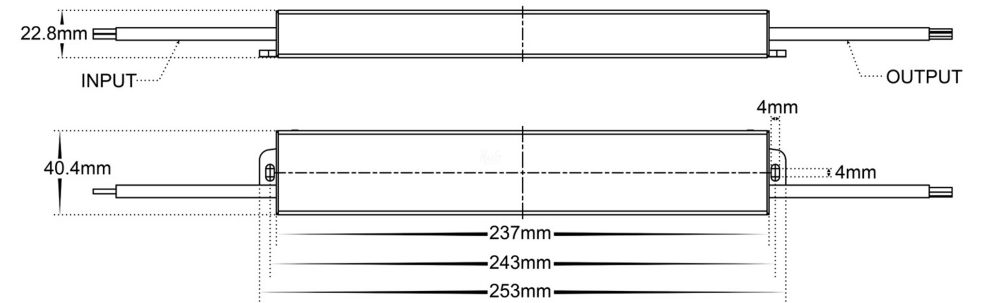

		HV9658-12V60WS	HV9658-24V60WS
Output	DC Voltage	12v DC	24v DC
	Voltage Tolerance	± 4V	± 2V
	Rated Current	5A	2.5A
	Rated Power	60W	
	Line Regulation	± 1%	
	No. Output Cables	1	
	Set up time	2000ms, 50ms(at full load) 110V AC / 230V AC	
	Holding time (Typ.)	15ms(at full load) 110V AC / 230V AC	
	Ripple and Noise(max)	120mVp-p	240mVp-p
	Load Regulation	± 2%	
Input	Voltage range Note 2	170~264V AC	
	Frequency Range	47 - 63Hz	
	Power Factor (TYP) @ Full Load	PF ≥ 0.9 / 230V (at full load)	
	Efficiency(Typ.)@ Full Load	85%	86%
	AC Current (Max)	0.37A / 230V AC	
	Inrush Current (TYP)	Cold start: 60A / 230V AC	
Leakage Current	<0.75mA / 240V AC		
Protections	Short Circuit	Hiccup mode, Recover automatically after fault condition is removed	
	Overload	110% - 130% of the rated output power	
	Over Temperature	Ta: 55°C ~ 65°C	
	Over Voltage	13-18V	24.5-35V
Environment	Working Temp.	Ta: -25°C ~ +50°C	
	Working Humidity	10%~90% RH, non-condensing	
	Storage TEMP. Humidity	-25°C ~+75°C, 5%~95% RH	
	TEMP. Coefficient	± 0.05%/°c (0-40°C)	
	Vibration	10~300Hz, 1G 10min./ 1 Cycle, Period for 60min, each along X,Y,Z axes	
Safety & EMC	Safety Standards	Compliance to EN61347-1, EN61347-2-13, AS/NZS61347-1, IP66 waterproof rating.	
	Isolation Resistance	I/P-O/P, I/P-FG, O/P-FG: 100Mohms/500Vdc 25°C /70%RH	
	Withstand voltage	I/P-O/P: 3.75KVAC I/P-FG: 1.875KVAC O/P-FG: 0.5KVAC	
	EMC Emission	Compliance to AS/NZS CISPR15	
	EMC Immunity	Compliance to AS/NZS CISPR15	

