

Tivah Double Adjustable Bollard Lights



Product Specifications

Name	Tivah
Material	316 Stainless Steel or Aluminium
Colour	Stainless Steel or Poly powder coated black
IP Rating	IP65
Installation Type	Ground - Surface Mounted
Lamp Base	GU10 or MR16
Max Wattage	GU10 - 2x 35w MR16 - 2x 20w
Protection Class	240v = 1 (Requires Earth) 12v DC = 3 (No Earth Required)
Lamp Expectancy	<30,000hrs
Diffuser Type	Clear Glass
Cable Length	2000mm
CRI	CRI>80
Dimmable	No - Not with supplied globes, See below for GU10 dimmable options
IK Rating	IK08
Warranty	3 Years Replacement*



316 Stainless Steel



Aluminium Black

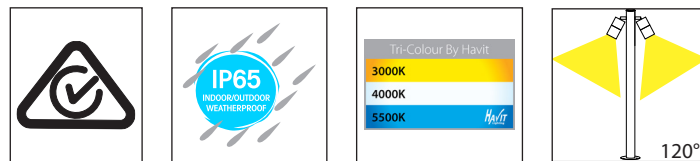

Optional Havit Compatible Accessories

Image	Part Number	Colour Temp	Input Voltage	Beam Angle	Included LED
	HV9506D	3000k 4000k 5500k	240v AC	60°	TRI Colour 3/5/7w GU10 LED
	HV9507 HV9508	3000k 4000k 5500k	12v DC 24v DC	60°	TRI Colour 3/5/7w MR16 LED
	HV9971	Stainless Steel Maintenance Kit - Kit includes rejuvenating paste + Spray for final protection coating			
	12v DC LED Drivers	See Catalogue or Website for full range of 12v DC LED Drivers			
	HV1607	Optional spike for installation into ground.			

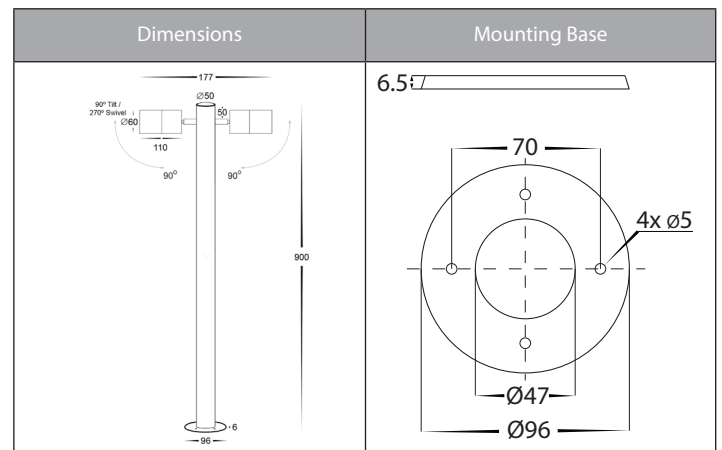

Product Ordering

Image	Part Number	Colour Temp	Lumens	Input Voltage	Beam Angle	Included LED	Barcode
	HV1507T-SS316-240V	3000k 4000k 5500k	2x 270lm 2x 285lm 2x 300lm	240v AC	120°	TRI Colour 2x 5w GU10 LED	9350418015976
	HV1507T-SS316-12V	3000k 4000k 5500k	2x 270lm 2x 285lm 2x 300lm	12v DC	120°	TRI Colour 2x 5w MR16 LED	9350418015969
	HV1507T-BLK-240V	3000k 4000k 5500k	2x 270lm 2x 285lm 2x 300lm	240v AC	120°	TRI Colour 2x 5w GU10 LED	9350418015952
	HV1507T-BLK-12V	3000k 4000k 5500k	2x 270lm 2x 285lm 2x 300lm	12v DC	120°	TRI Colour 2x 5w MR16 LED	9350418015945

*Items ordered after 01-01-2022

