

PUMP CONTROL

OWNER'S OPERATION MANUAL

**Advanced Dual Pump Controller
Installation and Operating Instructions**

MODEL: FPC-36240

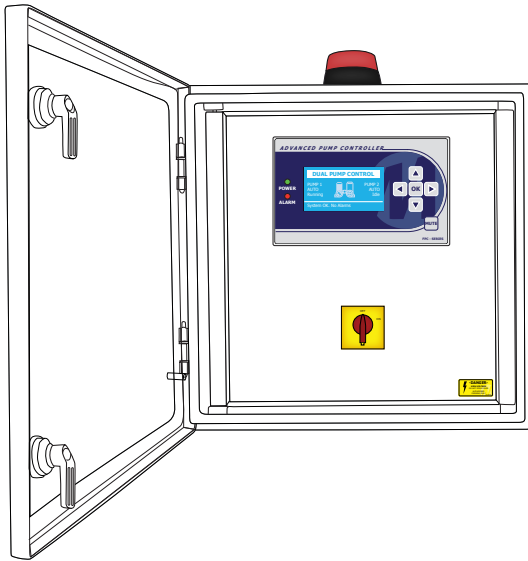

WARNING: All electrical connections must be carried out by a suitably qualified and registered electrician.

SAFETY



- Prior to Installation, ensure power supply is isolated.
- Power supply must be Circuit Breaker Protected. (Qualified Electrician to determine appropriate amp rating.)
- Electrical connection to the panel must be carried out in accordance with 'Connection Instructions', see page 3.
- Additions or modifications to the control panel are not permitted and will void warranty.
- The controller is not intended for use by children or infirm persons without supervision.
- Repairs to the Controller must only be carried out by a suitably qualified Electrician.

WELCOME TO DUAL PUMP CONTROL

Your Advanced Dual Pump Controller reflects the superior quality and attention to detail in design, engineering and manufacturing that has distinguished MATElec Products for decades. The controller incorporates the very latest in micro-processor technology, ensuring you, the owner/operator, of many years of functional, reliable and 'user friendly' operation.

Please read this manual prior to installation and operation of the controller.

INSTALLATION

MOUNTING

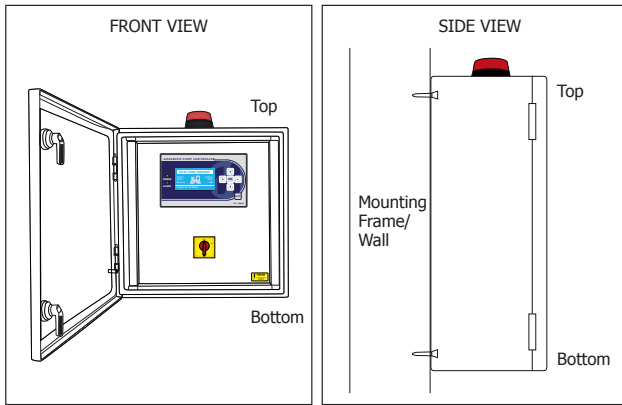

1. Controller enclosure must be mounted in a vertical position.
2. Ensure mounting method does not compromise enclosure weather proof rating.
3. Ensure access to main isolator is not restricted.
4. Ensure cables/conduits entering the panel have mechanical protection and that the penetrations are sealed and do not compromise the weather proof rating of the enclosure.

CONNECTION

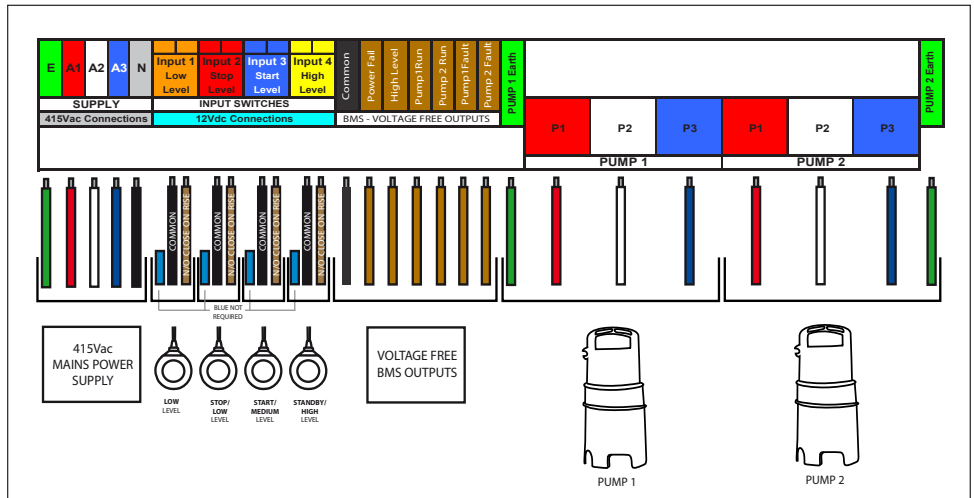

NOTE: Controller must be earthed and all electrical connections must be carried out by a suitably qualified Electrician. For Single Working Level Float Switch Applications, connect to "Start (Input 3)" terminals only, and NO bridge wire is required in "Stop (Input 2)" terminals.

CIRCUIT DIAGRAM

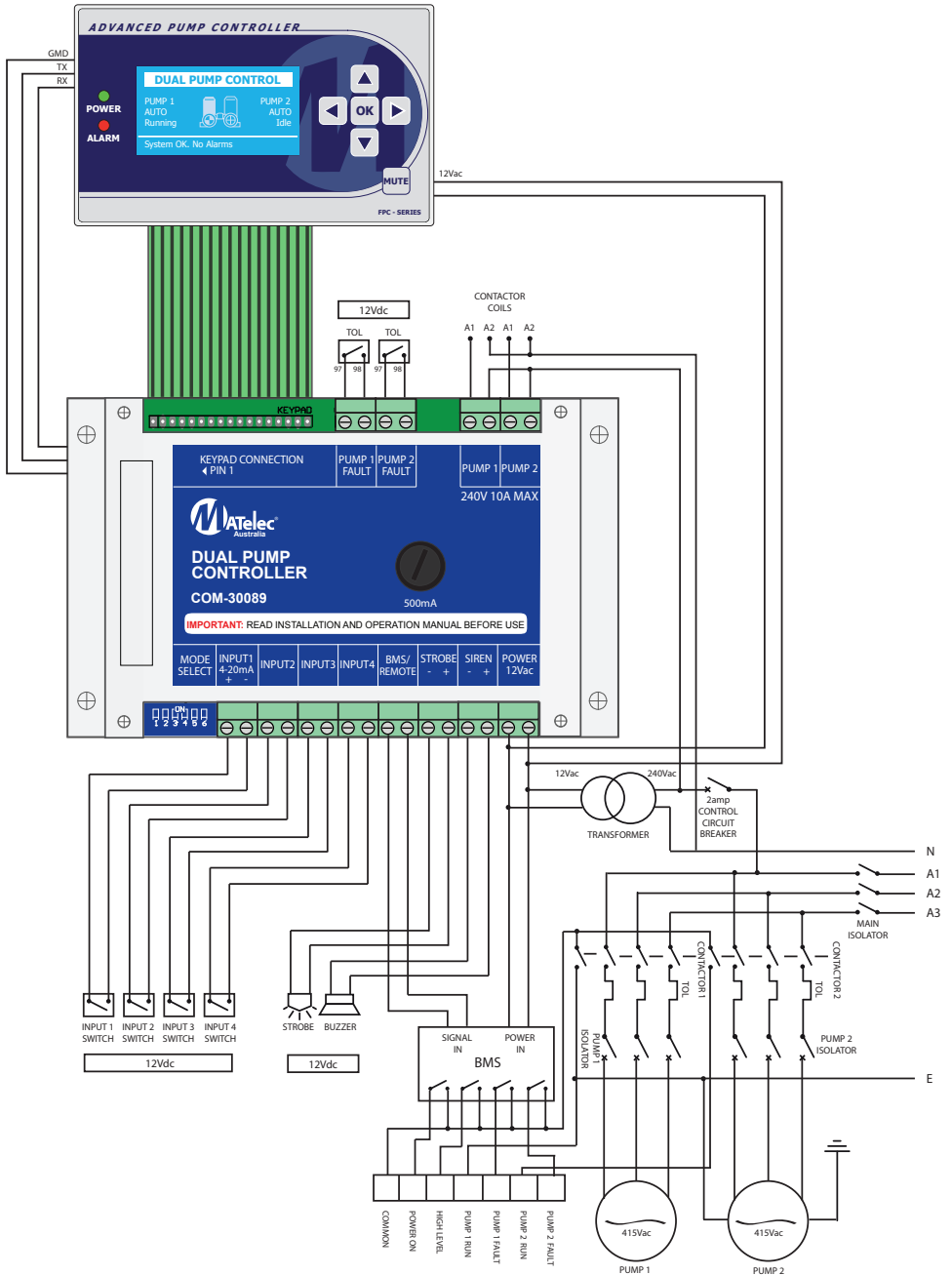

OPERATION

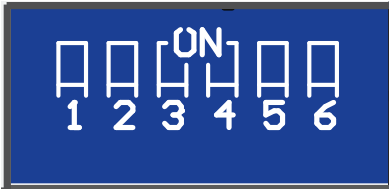

DIP Switches

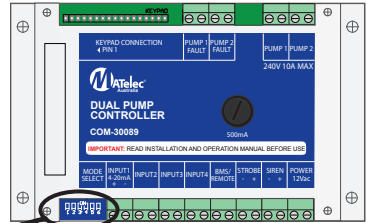

This controller can perform control functions for most Dual Pump pumping applications. It is more than likely that the control parameters have already been set up for your particular application, however, hereunder you will find details of the set up and configuration options.

There are 6 DIP switches located on the lower side of the control module, which allows for selecting "mode" and "feature" options, as per the following table:

DIP Switch	Position	Function
1/2	Off/Off	Mode A: Standard typical float switch configuration (Start, Stop and High Level). No Low Level
	Off/On	Mode B: Standard configuration plus low level (Start, Stop, High Level and Low Level).
	On/Off	Mode C: Standard configuration plus Prime Loss enabled, on Low Level (Input 1)
	On/On	Mode D: Pressure Pumping configuration (Lead, Lag and Low Pressure)
3	Off	Operating Pump alternates each time a pump start is triggered, or after 30 minutes continuous running.
	On	Operating Pump alternates after 6 hours continuous running.
4	Off	Anti-seize Timer disabled
	On	Anti-seize Timer 6 seconds every 7 days enabled
5	Off	When placed in Manual Mode, pump remains in Manual Mode
	On	When placed in Manual Mode after 5 minutes the pump will revert to Auto
6	Off	High Level Alarm automatically resets upon open circuit of high level input. High Level alarm has 15 minute delay.
	On	High Level Alarm can only be reset manually. High Level Alarm has 5 minute delay.

Mode A: Standard Configuration

Stop/Start/Standby/High Level operation. When the Pump Start input is closed contact (triggered), the Duty Pump will be turned on. The pump will remain on until both the Pump Start and Pump Stop Inputs have turned off (Open Circuited). Upon High Level, both pumps will run until the Pump Stop Input turns off.

In addition to this, there is a maximum idle timer, which will trigger a Pump Start condition, if either pump has not run for 4 hours, and the Stop Float Contacts are closed. The pump will continue to run until the Stop Float Contacts open. Input functions are as follows:

Input	Function
Input 1	Standby Start
Input 2	Pump Stop
Input 3	Pump Start
Input 4	High Level

Mode B: Standard Configuration plus Low Level Alarm

As per Mode A, except it has an active Low Level input. The Low Level input must be closed, for Pump Start and Pump Stop inputs to function. The High Level input however, will still override the Low Level and run both pumps. Input functions are as follows:

Input	Function
Input 1	Low Level
Input 2	Pump Stop
Input 3	Pump Start
Input 4	High Level

The basic logic on which a High or Low Level Alarm is determined, is set out in the Table below:

Input 1 Low Level	Input 2 Pump Stop	Input 3 Pump Start	Input 4 High Level	Pump State	Alarm
Closed	Open/Closed	Open	Open	Off	-
Closed	Open/Closed	Closed	Open	On	-
Closed	Open/Closed	Closed	Closed	Both On	High Level (after Timeout)
Closed	Open/Closed	Open	Closed	Both On	High Level (after Timeout)
Open	Open/Closed	Open	Open	Off	-
Open	Open/Closed	Closed	Open	Off	Low Level
Open	Open/Closed	Open	Closed	Off	Low Level
Open	Open/Closed	Closed	Closed	Both On	High Level (after Timeout)

If there is a Low Level Alarm, then both Pumps will be locked out until the alarm is manually reset. This lockout will only be over ridden upon a High Level condition where both the Pump Start and High level inputs are closed.

Note that after a High level is triggered, the pumps will both run until the Pump Start and Stop inputs are opened.

Mode C: Standard Configuration plus Prime Loss

As per Mode A, except Input 1 is connected to a prime loss/flow switch. If at any stage, after Pump Start, or whilst a pump is running, the Prime Loss input opens, for a continuous 1 minute period, a fault is immediately triggered for that pump and duty alternates. Input functions are as follows:

Input	Function
Input 1	Prime Loss
Input 2	Pump Stop
Input 3	Pump Start
Input 4	High Level

Mode D: Pressure Pumping Configuration

Duty Pump: Lead Pump

Standby Pump: Lag Pump

Input functions are as follows:

Input	Function
Input 1	Not Used
Input 2	Lead Pump Pressure Switch (set at say 350kPa)
Input 3	Lag Pump Pressure Switch (set at say 350kPa)
Input 4	Low Pressure Switch (set at say 200kPa)

Typical Operation for Mode D:

- Pressure drops to 400kPa: Lead (for this cycle) Pump cuts in.
- Pressure increases and Pump cuts out.
- Cycle continues with duty (Lead and Lag) alternating between the two pumps.
- If pressure drops to 350kPa, Lead Pumps will cut in and remain running until Lead Pressure Switch opens circuit. Then duty alternates.
- No faults are logged against the Lead Pump if the Lag Pump starts.
- The controller has inbuilt timers for "Delayed" Start and Stop to obviate pump chatter. Upon Input 1 contact closure, the pump will not start (delay start) for 1 second and will not stop (minimum run time) for 10 seconds (or 11 seconds from close of Input contacts). This "run on" occurs even if Lead Pressure switch opens circuit during this initial period. If however run time exceeds 11 seconds, the pump will stop immediately upon "Open Circuit" occurring.
- If the Lead Pressure Switch input closes circuit as well as the Low Pressure Switch input, both pumps will be turned on and the Low Pressure Timer will begin counting. If this condition exists for a period of 60 seconds, then both pumps are shut down and the system signals a level alarm. This would be typical of a Loss of Prime, or Burst main situation.
- Pressure switch contacts are Normally Closed and opened on High Pressure.

FEATURES

Maximum Run and Alternation Mode

With **DIP Switch 3** set to "Off" the unit will alternate as usual each time a pump start condition occurs. Additionally, the controller will automatically alternate pump duty if a pump has been running continuously for 30 minutes (maximum run timer) Setting this DIP Switch to "On" will cause the controller to operate in "Circulation Mode" where duty will only alternate once the pump has run for 6 hours of accumulated time.

Anti-Seize Timer

With **DIP Switch 4** set to "On", the Anti-seize timer will automatically run the pumps for 6 seconds, every 7 days. This pump operation will completely override all inputs including the low level (if enabled). This feature will only run pumps that are set in Auto. This "Pump Run", will alternate between Pump 1 and Pump 2. A pump that has been locked out due to a fault will not run.

Manual Mode Timeout

With **DIP Switch 5** set to "On" the pump will only remain in Manual Mode for 5 minutes, after which time, it automatically reverts to Auto.

High Level Alarm Reset

With **DIP Switch 6** set to "Off", the High Level Alarm will automatically reset once the High Level input opens circuit. The controller will also use the alternate High Level Alarm Delay. Typically used for Storm Water applications. High Level Alarm delay in this mode is 15 minutes.

Setting this DIP Switch to "On", will cause the High level Alarm to remain active until the controller is reset. The High Level Alarm will use the standard High Level Alarm activation delay. Typically used for Sewerage applications. High Level Alarm delay in this mode is 5 minutes.

HMI OPERATION

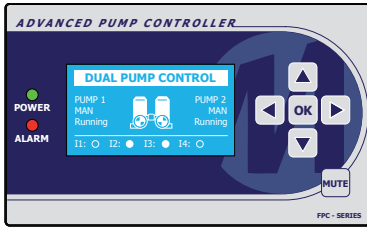

The HMI

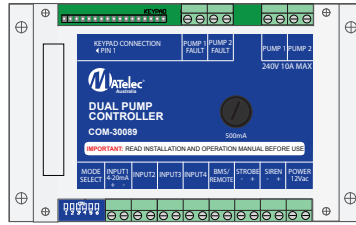

The Controller

When power is applied the HMI immediately starts up, displaying a “splash screen” with the Matelec logo and software revision is displayed for several seconds. Once the splash screen disappears the HMI will then display the main screen which gives an overview of the system.

While the HMI is operating it must always be connected to a controller in order to read the necessary data that it needs to display. If it is unable to communicate with the controller the HMI will begin to flash both indicator LEDs and notify the user on the LCD. The user will be unable to operate the HMI until the communication link is restored.

During normal operation the user is able to access many different functions related to both the attached controller and the Modbus interface. The following sections present the various menus used by the HMI and describe their use. Navigation between the menu screens is performed using the left and right arrows, which cycles through each of the screens in the following order:

1. Main screen (pump auto/off/manual control)
2. Alarms
3. Input and 4-20mA states
4. View logged data
5. Reset logged data *
6. View functional parameters
7. Edit functional parameters *
8. Edit configuration settings *
9. System information and serial number *

* Lines marked with an asterisk require entry of a PIN number for access.

Note that many of the menu screens feature a prompt along the bottom of the display which outlines basic button functions.

1.1 Main Screen

The HMI main screen provides the overall system status and allows the user to change the auto/off/manual settings for each pump. Pressing “OK” while on the main screen will allow the user to select the mode for both pumps, as shown in the image on the right:



Main Screen

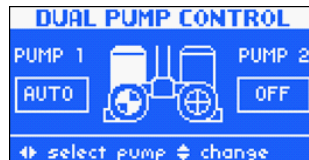

Main screen auto/off/manual select

During pump mode selection the mode of the selected pump (AUTO, OFF or MANUAL) will flash. Pressing the up and down buttons will change the mode of the selected pump, whereas pressing the left and right buttons will select the pump. Pressing OK will accept the selection and return to the main screen.

1.2 Alarms

The alarms screen reports any alarm conditions and provides the user with a method to reset them. If there are no alarms active then the screen will appear as shown on the left image. This provides an opportunity for the operator to

trigger an alarm test. Pressing the OK button will cause the controller to activate its siren and strobe outputs, plus all LEDs on a keypad (if used) for 5 seconds. After this alarm test completes the alarms will return to normal operation.



Alarms screen with no alarms

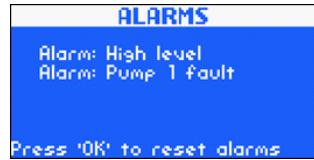

Alarm screen with multiple alarms

If any alarms are active the alarm screen will appear as shown on the right image above and list up to 5 of the active alarms.

When an alarm triggers the controller will activate its siren and strobe outputs. The alarm LED on the HMI will also flash. The siren will silence after 5 minutes of continual sounding, however it can be immediately silenced by pressing the mute button on the HMI.

Most alarms in the controller are latching, that is the alarm remains active even if the alarm condition has passed / corrected. In order to reset the alarm the OK button needs to be pressed when the Alarms screen is selected.

1.3 Input States

The Input States screen simply gives a readout of all controller inputs, including the operation mode DIP switches and current loop. If the current loop is disabled it will be mentioned on the screen, otherwise both the current and the level (or pressure, depending on the configuration) will be reported. There are no user actions on this screen.

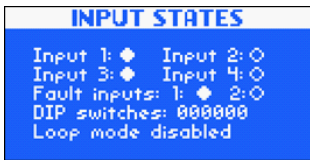

Input states without current loop

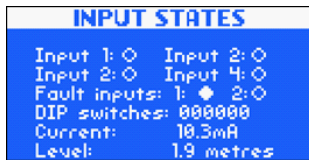

Input states with current loop

1.4 Logged Data

The logged data screen displays a list of all logged data values from the controller. The up and down buttons are used to scroll through all of the values – a small up or down arrow will appear on the top or bottom of the left side of the screen while there is more data available in that direction.



Logged data screen

1.5 Reset Logged Data

The Reset Logged Data screen allows the user to selectively reset logged data values to zero. There are four options given: reset all, reset all excluding pump run hours, reset pump 1 run hours and reset pump 2 run hours. The up and down buttons are used to select one of these options, which is then selected using the OK button.



Logged data reset selection screen

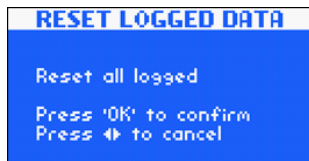

Logged data reset confirmation screen

A confirmation screen is presented before the data is actually reset: the OK button is pressed to confirm resetting the selected logged data values or one of the left or right arrows are pressed to cancel.

Note that before this screen can be accessed a PIN number has to be entered (as discussed in section 5.6).

1.6 Function Parameters

The Function Parameters screen operates identically to the Logged Data screen, but instead presents all of the operation parameters for the controller. Refer to the APC6 specifications for details regarding each of the parameters. The up and down buttons are used to scroll through the list.

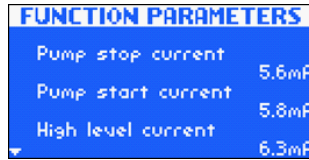

Function parameters screen

1.7 Edit Parameters

The Edit Parameters screen allows the user to modify any of the function parameters in the controller. The parameter that the user wishes to modify is highlighted using the up and down buttons and then OK is pressed in order to edit the selected parameter.

Once a parameter has been selected the screen on the image to the right below will be presented and the up and down arrows can then be used to modify the value. The new value can be committed to the controller by pressing OK, otherwise the operation can be cancelled by pressing one of the left or right buttons.



Parameter selection screen

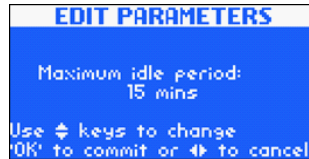

Parameter modify screen

As with the Logged Data Reset, this screen requires entry of a PIN number for editing.

1.8 Edit Config Settings

All of the configuration settings related solely to the HMI can be modified through this screen. The Modbus configuration options are listed below and there are three additional configuration settings in the list:

1. **Set 4-20mA level range:** this setting specifies the maximum range of the pressure transducer being used to sense the liquid level, based on the level mode selected. For example, if a 0-10m probe is used, then the range would be set to 10m. Alternately, if a 0-1000kPa probe is used, then the range would be set to 1000kPa.
2. **Set 4-20mA level mode:** this setting specifies the level mode for the system – metres or kilopascals (kPa). All references to the transducer output will be displayed based on this parameter.
3. **Change PIN:** selecting this option will allow the PIN number to be changed.

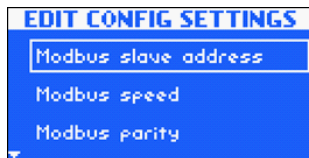

Configuration edit screen

1.9 System Information

The final screen in the list is the System Information screen, which reports serial number and firmware revisions for the controller and HMI. Note that the HMI does not include a serial number of its own – the serial number value here is supplied by the controller.

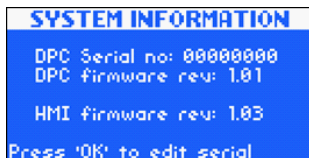

System information screen

The system information screen also facilitates changing the serial number – this is done by pressing the OK button. Note that the PIN number is required to change the serial number.

1.10 PIN Number

In order to modify anything other than the pump auto/off/manual settings, the operator must enter a 4-digit PIN number. Once the PIN is correctly entered, the system remains unlocked for 15 minutes, after which the PIN will need to be entered once again. While unlocked the PIN number can be modified through the configuration settings edit menu.



PIN entry screen

To enter the PIN number, simply use the left and right buttons to select the digit and the up and down buttons to change the digit.

The default PIN number is 1234.

Note that there is no penalty for entering an incorrect PIN – the HMI will simply return to the previous screen and the opportunity to enter the PIN will again be presented.

1.11 4-20mA Display Modes

When the APC6 current loop mode is enabled the HMI is able to report the current 4-20mA reading (this is shown on the inputs menu screen). In addition, it can convert this reading into one of two types of scale: metres or kPa. The metres scale can be adjusted for a maximum range of 0.1 to 25.0 metres (in 0.1m increments) and the kPa scale can be adjusted for a maximum range of 10 to 2500kPa in 10kPa increments.

MODBUS COMMUNICATIONS

Modbus is a serial communications protocol originally designed for use PLCs. Simple and robust, it has since become one of the de facto standard communications protocols in the industry, and it is now amongst the most commonly available means of connecting industrial electronic and control devices.

There are several different variations of the Modbus standard based around the transmission mode and data encoding technique. The protocol supported by this HMI is Modbus RTU, which is in a binary format sent over a serial link. The HMI is configured as a Modbus slave and responds to commands sent to it from the Modbus master.

2.1 Modbus Settings

In order to reduce unnecessary complexity, the system is compatible with with the BASIC Modbus implementation class with some additional features, as detailed in the following table. All settings have a default which is valid until the operator changes them via the configuration menu.

Setting	Implemented	Default
Address	Configurable from 1 to 247	1
Baud Rate	9600, 19200	19200
Parity	Even, Odd, None	Even

2.2 Modbus Physical Connection

The HMI provides a three pin pluggable terminal for connection of the three RS-485 connections required for the Modbus interface: A, B and GND. As with the other HMI connections the wiring information is printed on the rear label of the unit.

2.3 Modbus Poll and Timeout Settings

The poll rate is how often the Modbus master requests information from the slave. Since the processor on the HMI must also operate the user interface and continually operate the communication link with the connected controller, it is only able to cope with a limited number of Modbus transactions per second. The recommended maximum poll period of 500ms (2 polls per second), however a period of 1 second is preferred. Periods as low as 250ms can be achieved but there can be no guarantee as to the HMI's ability to respond at this rate (particularly with write commands).

Certain Modbus operations require the HMI to initiate further communications with the attached controller and this can take significantly more time than other operations for the controller to respond. For this reason a timeout period of no less than 1000ms should be used. If the Modbus connection is being used for monitoring only (rather than monitoring and control) then the timeout can be reduced to 500ms.

2.4 Modbus Supported Function Codes

The Modbus protocol uses function codes to perform actions such as reading and writing the different physical data types. Only a portion of the full range of function codes is used, as outlined in the following table:

Function Code	Description	Valid Address Ranges
01	Read coils	1 to 8, 17 to 24, 33 to 38
03	Read holding registers	1 to 3, 17 to 46, 65 to 78
05	Write single coil	49, 65
06	Write single register	65 to 78 *
16	Write multiple registers	65 to 78 *

* Address ranges marked with an asterisk can only be written to with the value 0x0000 for logged data or 0x0000 to 0x0002 for pump modes.

2.5 Address Reference

The following tables list all valid Modbus coil and register addresses for the Controller and the data contained within:

APC6 Modbus Coils		
Address	Parameter	Access
1	Input 1 state	Read Only
2	Input 2 state	Read Only
3	Input 3 state	Read Only
4	Input 4 state	Read Only
5	Pump 1 fault input state	Read Only
6	Pump 2 fault input state	Read Only
7	Pump 1 output state	Read Only
8	Pump 2 output state	Read Only
17	High level fault	Read Only
18	Low level fault	Read Only
19	Pump 1 fault	Read Only
20	Pump 2 fault	Read Only
21	Low pressure fault	Read Only
22	Pump 1 prime loss fault	Read Only
23	Pump 2 prime loss fault	Read Only
24	Inhibit fault	Read Only
33	Single pump mode enabled	Read Only
34	Current loop mode enabled	Read Only
35	Mute state	Read Only
36	Alarm test active	Read Only
37	Inhibit fault enable	Read Only
38	Pump inhibited	Read Only
49	Set mute	Write Only
65	Reset alarms	Write Only
APC6 Modbus Registers		
Address	Parameter	Access
1	I/O states	Read Only
2	Alarm states	Read Only
3	System states	Read Only
17	4-20mA reading x0.1mA	Read Only
18	DIP switches	Read Only

19-22	APC6 Serial number (2 characters per register)	Read Only
23-24	APC6 Software rev (2 characters per register)	Read Only
25-26	ME16 Software rev (2 characters per register)	Read Only
27	Pump stop current x0.1mA	Read Only
28	Pump start current x0.1mA	Read Only
29	High level current x0.1mA	Read Only
30	Antiseize period	Read Only
31	Antiseize run time	Read Only
32	Manual mode timeout	Read Only
33	Standard mode maximum run time	Read Only
34	Recirc mode maximum run time	Read Only
35	Maximum idle period	Read Only
36	High level alarm delay	Read Only
37	Pump fault delay	Read Only
38	Prime fault delay	Read Only
39	Pressure mode start delay	Read Only
40	Pressure mode min run time	Read Only
41	Pressure mode alarm delay	Read Only
42	Alternate high level alarm delay	Read Only
43	Single pump mode enabled	Read Only
44	Inhibit trigger delay	Read Only
45	Inhibit fault enabled	Read Only
46	Inhibit fault threshold	Read Only
65	Pump 1 mode	Read/Write
66	Pump 2 mode	Read/Write
67	Pump 1 run hours	Read/Write
68	Pump 2 run hours	Read/Write
69	Pump 1 start count	Read/Write
70	Pump 2 start count	Read/Write
71	Pump 1 fault count	Read/Write
72	Pump 2 fault count	Read/Write
73	High level count	Read/Write
74	Low level count	Read/Write
75	Power cycle count	Read/Write
76	Low pressure alarm count	Read/Write
77	Pump 1 prime loss count	Read/Write
78	Pump 2 prime loss count	Read/Write

DISTRIBUTED BY:

INSTALLATION DATE:
SERIAL NUMBER:

MANUFACTURED BY MATElec AUSTRALIA

EMAIL: info@matelecaustralia.com.au

MATElec reserves the right to alter technical specifications without notice