

Warranty

Brilliant Lighting warrants this product against defects in manufacture and workmanship for a period of 2 years from date of purchase. Warranty does not include damage or loss arising from incorrect installation, operation or maintenance of this product, damage caused through modification, or incorrect installation.

Our goods come with guarantees that cannot be excluded under the Australian Consumer Law. You are entitled to a replacement or refund for a major failure and compensation for any other reasonably foreseeable loss or damage. You are also entitled to have the goods repaired or replaced if goods fail to be of acceptable quality and the failure does not amount to a major failure.

Any claim under this warranty must be made within 2 years of the date of purchase of the product.

Refer to our website brilliantlighting.com.au for terms and conditions and warranty claims.

This warranty is given by:

Brilliant Lighting (Aust) Pty. Ltd.

ABN 37 006 203 694

956 Stud Road Rowville, VIC 3178

Phone: 03 9765 2555

Email: warranty@brilliantlighting.com.au

MADE IN CHINA

Warning

1. To prevent injury, this apparatus must be installed by a Licensed Electrical Contractor.
2. For Indoor use only.
3. Please make sure the glass wall switch is not overloaded. Working power cannot be higher than the rated power (100W LED, 500W Incandescent)
4. Do not attempt to press touch switch at very high frequencies (faster than one switch per second) as this may result in premature failure.

Brilliant Lighting

956 Stud Road
Rowville Vic 3178 Australia

www.brilliantlighting.com.au

Australian Sales

T 03 9765 2555
T 1800 817 754 (interstate only)
F 03 9763 0277
E sales@brilliantlighting.com.au

New Zealand Sales

T 09 974 9618
E sales@brilliantlighting.com.au

1889P 01/19 00



GLASS WALL SWITCH

20682/05, 20684/05,
20686/05, 20688/05



USER MANUAL

Box content

Glass Wall Switch x 1
User Manual x 1

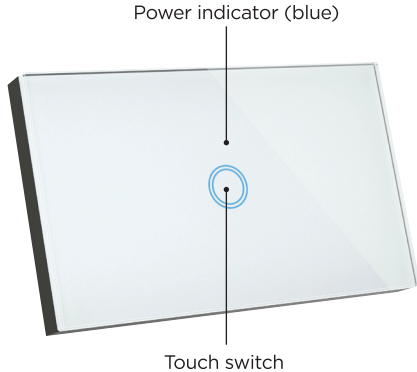

Technical Specifications

Model Number: 20682/05, 20684/05, 20686/05, 20688/05
Colour: White
Supply voltage: 240V AC 50Hz
Max. load: 500W Incandescent or 100W LED per gang
TA: 0...+35°C

Installation

THIS FITTING MUST BE INSTALLED BY A QUALIFIED ELECTRICAL CONTRACTOR in accordance with the latest AS/NZS 3000 and relevant amendments

Important Safety Issues

Ensure the power is disconnected before installing. This product is NOT suitable for damp or explosive environments. Modification of this product will void any warranty. Indoor use only. Do not cover in insulation.

Product Features

- Three wire design (Neutral required).
- Class II Construction.

Installation

The glass wall switches are designed to fit standard wall switch cutouts, and plaster/stud brackets with 84mm centres.

Remove the front glass by inserting a flat blade screwdriver into the recess on the side of the switch, twist and remove.

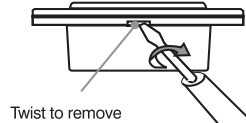

Connect the active incoming supply to L and N and Earth using the 20mm² terminals.

Wiring Diagram

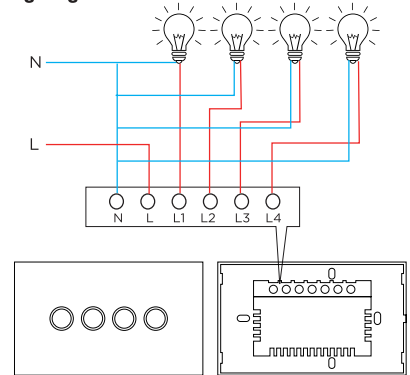

Insert the glass wall switch onto the wall, aligning the 84mm mounting holes with the plaster/stud bracket holes.

Tighten the mounting screws and replace the cover by clipping on one side followed by the opening side last.

