

FNCFDR FNCFDS FNCFDG



Cleaning Guide:

See instructions with product packaging

Falcon Ceiling Exhaust Fan Ducted

- Ideal for rapid removal of steam and odours
- Easy to clean grille
- Quiet operation
- Built in non-return draft excluder
- Retro-fit for 295mm round cut-out
- Plug and lead fitted
- No duct included (150mm duct compatible)
- Suitable for ceilings between 5mm and 12mm
- 60 Watt Ball Bearing Motor
- Ducting Outlet Ø150mm
- Airflow 350 m³/h
- Cutout size Ø295mm
- **FNCFDG** (Grille) - includes fly mesh and duct clamps (150mm duct compatible)

Catalogue Number	Description
FNCFDR	Ceiling Exhaust Fan Ducted, Round
FNCFDS	Ceiling Exhaust Fan Ducted, Square
FNCFDG	Ceiling Exhaust Fan Ducted, Grille

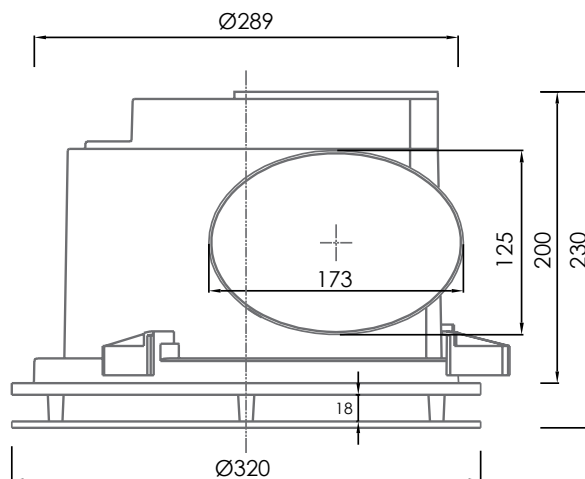

Certification Number: SAA-190785-EA

GSM Electrical (Australia) Pty Ltd

Level 2, 142-144 Fullarton Road, Rose Park SA 5067

P: 1300 301 838 F: 1300 301 778 E: service@gsme.com.au

www.gsme.com.au



FNCEF200 FNCEF250



Cleaning Guide:

See instructions with product packaging

Falcon Ceiling Exhaust Fans

- Easy to clean clip on grille
- High performance ball bearing motor
- Compatible with our Hyena Surface Sockets

FNCEF200 - Ceiling Exhaust Fan 200mm

- **Cut out size: Ø 240mm / Overall diameter 300mm**
- 107mm product height without fascia
- 117mm product height including fascia
- 100mm minimum height clearance from rooftop to ceiling
- 214mm air outlet diameter
- Air flow 240m³ per hour
- 25 Watt ball bearing motor



Easy to Clean Grille

FNCEF250 - Ceiling Exhaust Fan 250mm

- **Cut out size: Ø 290mm / Overall diameter 355mm**
- 103mm product height without fascia
- 112mm product height including fascia
- 100mm minimum height clearance from rooftop to ceiling
- 270mm air outlet diameter
- Air flow 401m³ per hour
- 35 Watt ball bearing motor



High Performance Ball Bearing Motor



Frame design has rotating clamp lugs for ease of installation.

Cross Reference Chart

Trader	Clipsal*
FNCEF200	CE200
FNCEF250	CE250

Catalogue Number	Description
FNCEF200	Ceiling Exhaust Fan 200mm
FNCEF250	Ceiling Exhaust Fan 250mm

*The Clipsal brand and associated products are registered trademarks of Schneider Electric (Australia) Pty Ltd. GSM Electrical (Australia) Pty Ltd, the TRADER brand and its products, have no endorsement or affiliation with Schneider Electric Pty Ltd.

Certification Number: SAA-172363-EA

GSM Electrical (Australia) Pty Ltd
 Level 2, 142-144 Fullarton Road, Rose Park SA 5067
 P: 1300 301 838 F: 1300 301 778 E: service@gsm.com.au
www.gsm.com.au



Data Specification Sheet
May 2019

